

**OfficeZone.com™**

**1-800-543-5454**

**(801) 927-3026**

## **Number-Rite Electric Numbering Machine**

### **General Description and Operating Instructions**

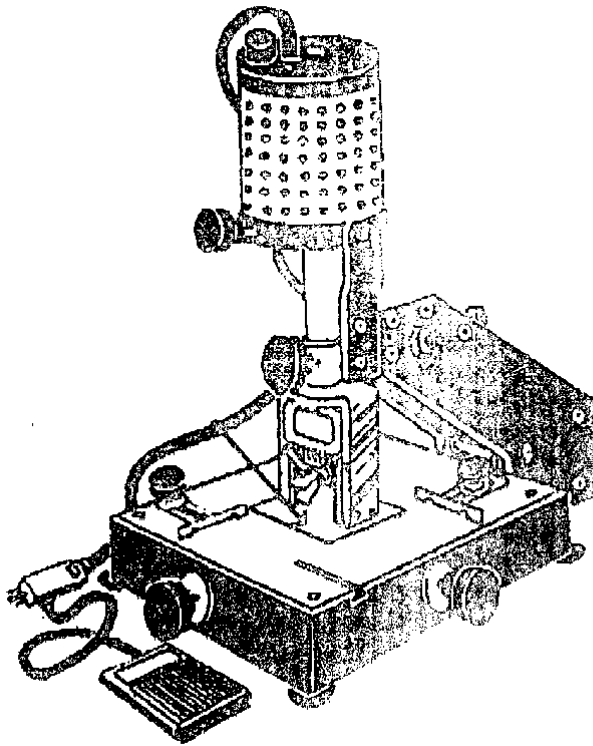

General Description: This electric numbering machine is rapid, accurate and has the capability of numbering up to 1000 pieces per hour by means of a footswitch, which leaves both hands free to handle the paperwork. This sturdy, high quality machine numbers from 1 to 999999.

Two moveable paper guide stops (6) are provided to ensure correct position of the paper. The numbering head can be rotated through 360° so that numbers can be placed anywhere on the sheet on any axis. The head has six figure wheels in Gothic style numbers, (Roman style numbering head available). Number impression goes through 8-part NCR.

Accurate alignment between print head and strike pad is achieved by means of adjusting knobs; front, side and rear (1 2 3).

## Numbering Head Preparation

### Release the head

- Lower head (5) by pressing stylus into access hole (20), move the tab on the back side of head, to the lock position.
- Press down on the rear control knob (3) to release the head and move it up to a horizontal position so that the numbers will be exposed.

### Setting the figures

- Set the figures to the desired position by pushing with the stylus provided.

Caution – Use only the stylus provided to move numbering wheels. Metal rods or tools are too hard and may damage numbers. Turn numbering wheels toward ink pad only. Damage may result if turned in opposite directions.

- If a numbering column(s) are not necessary (outside of the first column), turn the desired wheel(s) to zero in those columns and press down and slightly forward on the zero with the stylus. The zeros will be recessed and the column(s) will not appear in the impression.

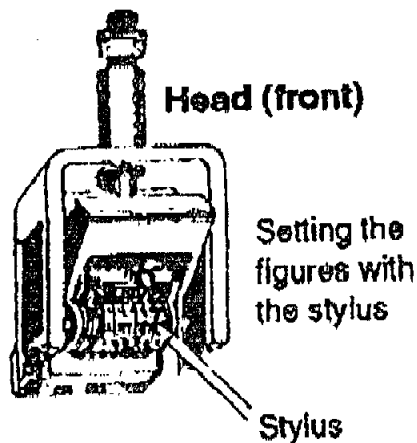

### To rotate the numbering head

- Loosen the knobs (4 and 7).
- Turn head to desired position and tighten the two knobs again. Resume numbering.

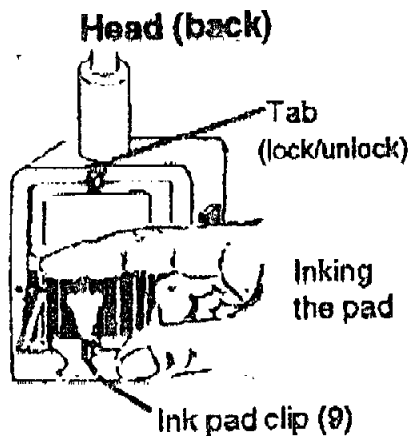

**To replace the ink pad**

- Pinch the clip (9) (on back side) to remove the felt pad.
- Ink the pad as required and replace it. (The ink pad clip is slightly longer than the felt pad.)  
Caution – Use standard metal numbering machine ink only. Rubber stamp ink will clog numbers.

**To set number repeat action**

- Lift indicator (E1), unclasp
- Slide indicator along the index plate (E2) to desired numbering sequence.

After completing the above head preparation steps, move the tab on the back side of the head, to the unlock position to release the head.

|                                      |                          |                          |
|--------------------------------------|--------------------------|--------------------------|
| Settings for Repeat Action Numbering | 0 Repeat the same number | 1111111111111111         |
| .....                                | 1 Consecutive            | 123456789 10 11 12       |
|                                      | 2 Duplicate              | 112233445566778899       |
|                                      | 3 Triplicate             | 111222333444555666777888 |
| Use Action Indicator                 | 4 Quadruplicate          | 111122223333444455556666 |
|                                      | 6 Sextuplicate           | 111111222222333333444444 |
|                                      | 12 Twelve Repeats        | 111111111111222222222222 |

**To remove the numbering head**

- Press down on the control knob (3) located at the rear, a latch will release the head and enable it to move up to the horizontal position
- Unscrew the four retaining screws (17) on the yoke (16), which hold the head in place. Remove.
- Remove the adapter nut (A), jam nut (B), spring (C), and spring holder (D).

Caution – Make certain the compression spring (shown below) is properly seated on the adapter nut (A) before reinstalling the head.

Assemble new head by reversing the above procedure. Install head into yoke.

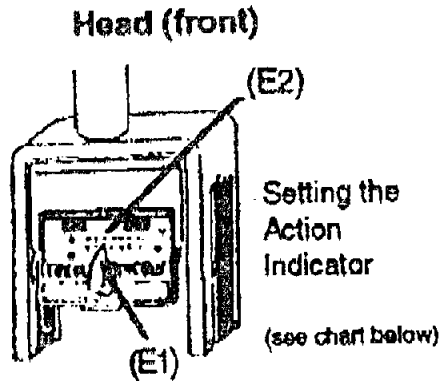

**Adjusting the Strike Area**

The Number-Rite has an adjustable strike area (5), controlled by three adjusting knobs: front (2), side (1), and rear (3). This allows you to control the quality of the applied numbers. Proper adjustment of these knobs will permit successful numbering on a full range of jobs, from a single page of delicate paper to printing through 8 part NCR forms. The three adjustments as set at the

factory will take care of most jobs. However, by observing a few trial numbers, the Number-Rite can be re-adjusted for best results on your particular jobs.

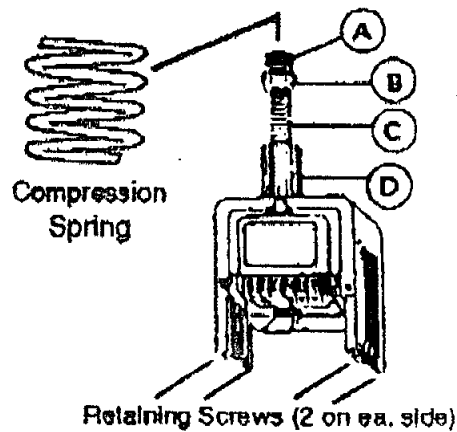

#### Paper Guides

- Position paper guide stops (6) on the table surface so the numbers are printed in the desired location
- There are two paper guide stops included with your machine

#### Striking force adjustment

- Knob (2) on the front of the machine controls the striking force of the numbering head.
- To INCREASE the striking force, the platen with the green strike pad (8), is raised by turning this knob (2) counter-clockwise. Whenever the front knob is turned it is usually necessary to adjust the vertical alignment of the head by turning knob (3) on the rear of the machine.
- If the head moves back while numbering, turn tension screw (12) clockwise. This will add tension and prevent head from moving backward

#### You must clean and oil the numbering head

- Scrub the head with a non-metallic brush and numbering machine cleaner.
- You may use either a combination type of cleaner with oil and cleaner in one.
- If you use a numbering head clean that is not an oily mixture, then you MUST OIL the head after cleaning it. Use a lubricant that is not affected by cleaning solvents.

Caution – Press wash can damage the head.

**Important** – Suction Feet (19) should be cleaned periodically to ensure proper suction to a smooth working surface. Improper gripping of the suction feet to the work surface may result in poor numbering such as a double image.

#### Connecting power source

- Plug cord front numbering machine into foot pedal (18)
- Plug foot pedal into electrical outlet.

Caution – Never plug machine directly into electrical outlet.

**Trial Numbering...**

1 2 3 4 5 6 Top light ... turn front knob clockwise (2)  
 Top dark ... turn front knob counter-clockwise (2)

1 2 3 4 5 6 Top too light ... turn rear knob counter-clockwise (3)  
 Bottom too light ... turn rear knob clockwise (3)

1 2 3 4 5 6 Left too light ... turn side knob clockwise (1)  
 Right too light ... turn side knob counter-clockwise (1)

1 2 3 4 5 6 Correct register ... no adjustment necessary

**Parts...**

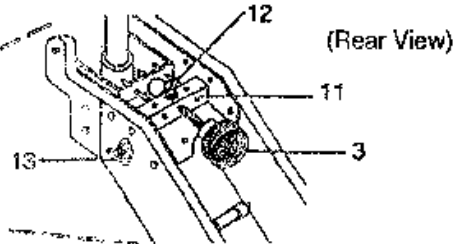
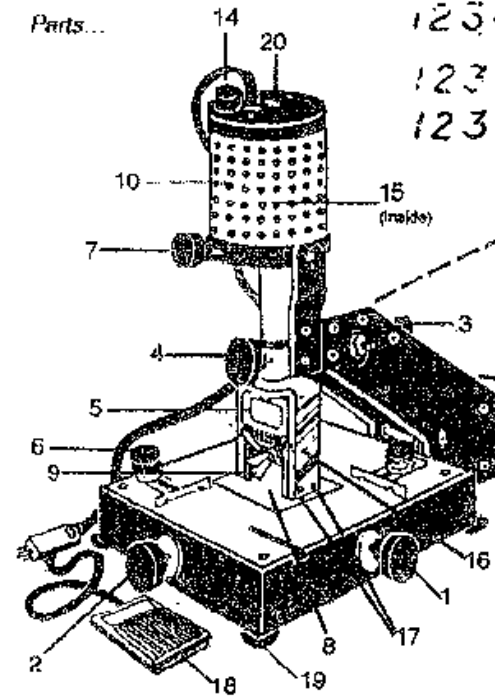

- |   |                         |
|---|-------------------------|
| 1 Side Knob (horizontal alignment)      | 11 Hinge Assembly       |
| 2 Front Knob (raises/lowers strike pad) | 12 Tension Screw        |
| 3 Rear Knob (vertical alignment)        | 13 Set Screw            |
| 4 Knob (loosen/tighten head)            | 14 Fuse Holder/Fuse     |
| 5 Numbering Head                        | 15 Solenoid (inside)    |
| 6 Paper Guide (2)                       | 16 Yoke                 |
| 7 Knob (loosen/tighten head)            | 17 Retaining Screws (4) |
| 8 Strike Pad (green, 2-3/4")            | 18 Foot Pedal           |
| 9 Ink Pad Clip                          | 19 Suction Feet (4)     |
| 10 Grill Cover                          | 20 Access Hole          |